

TRIMBOT MECHATRONICS STATION  
FOR TRIMMING AND SAMPLING WIRE RODS IN THE COIL HANDLING AREA

BY

MARCO CAPITANIO\*

JENS NYLANDER\*\*

SYNOPSIS:

Wire rod mill technology has improved significantly over the past several decades by introducing state-of-the-art technology, innovative and novel processes and automation. In spite of this, the head and the tail of finished coiled products still suffer from imperfections which must be trimmed and removed.

The trimming and sampling are almost always performed by manual operators using hand tools. These operators perform a delicate and dexterous process on a hot product in a hazardous working environment under time-pressure. Naturally, under these conditions, mistakes are made, potentially leading to reduced profitability and injuries to the operators.

This prompted AIC to develop the TRIMBOT. An all-electric patent-pending system combining mechatronics, industrial robotics and 3D vision systems with a high level of automation and artificial intelligence.

The fully autonomous system introduces a novel process, making it possible to trim and sample the head & tail of these coils with exceptional accuracy and for the first time, it can be performed while the coil remains vertical. Its dynamic ability allows the system to adjust the trimming position based on real-time production parameters in the rolling mill, and it's designed to fit on the existing mill-floor in virtually any type of coil handling system.

**Keywords:** Trimming & Sampling systems, Material Handling, Robotics application, Rolling Mill, Automation, 3D Vision System, Pinch-roll, Wire Rod Coils, Rings, Billets, Processing Turret, Safety

\* CEO, AIC Group – Automazioni Industriali Capitanio, Brescia, Italy

\*\* Engineering Supervisor, AIC Group – Automazioni Industriali Capitanio, Lycksele, Sweden

## INTRODUCTION

This paper presents a novel, patent-pending, Autonomous Trimming & Sampling Station which is introduced on the market as the TRIMBOT.

Conventional trimming & sampling stations are typically located within the confines of the coil handling system. It is predominantly a manual activity where at least one operator identifies, separates, cuts and removes anything ranging from a short piece of a ring to several rings from the exposed end of a wire rod coil. This manual activity offers very poor working conditions and is a frequent source of different types of injury to the operators. There is also a negative impact on yield, waste and product quality as individual operators may interpret and implement trimming instructions different from their co-workers. Trimming too much will reduce the yield and creates excess waste, not trimming enough creates additional cost or downgrading of the entire coil.

The manual trimming & sampling activity is also expensive to operate, without adding any particular value to the finished product. When summarizing, the total cost of the rolling mill operation, originating from manual trimming & sampling, is significant.

The system presented in this paper introduces a novel process, designed to circumvent most challenges associated with conventional coil trimming by transforming the manual workstation into a completely Autonomous Trimming & Sampling Station. The TRIMBOT process transforms the rudimentary trimming & sampling activity into a dynamic resource in the conversion of billets into a high-value finished product. For example, manual trimming offers a trimming accuracy of +/- one loop (approx. 3400 mm). In comparison, the TRIMBOT accuracy can be as low as +/- 5 mm.

The TRIMBOT brings several new abilities to the trimming and sampling process. The Dynamic Ability enables it to regulate its process based on variations in the rolling mill process, from one coil to the next. Equipped with suitable sensors, it can perform real-time measurements on the finished product, and for the first time, trimming & sampling can be performed on a vertical coil.

## DISCUSSION

### BACKGROUND

In a modern Wire Rod Rolling Mill, there are no humans actively working the equipment during production, operators are supervising the process from control rooms at a safe distance from any dangerous equipment; the only time people are allowed near the rolling equipment is during maintenance, repair or when equipment is removed, replaced or adjusted. This has allowed the process and the technology to evolve, and a modern Wire Rod Rolling Mill produces a higher quality product at a higher production rate with a higher yield, using fewer people while offering a safer workplace.

The story is quite different once the rings are formed into a coil and enter the coil handling and packaging area. In this area of the long rolling mill, the process often requires humans to actively participate in the work on the rolled product.

As a result of people working intensively within the coil handling system, there are more frequent injuries such as lacerations, burns and crushed limbs; by relying on human operators to actively take part in the process, there is also the exposure to mistakes which always result in increased operating costs.

In a modern coil handling system, manual activities normally include:

- Collection of a sample for upset-test
- Coil shape inspections
- Head and tail trimming
- Collection of sample wire for analysis
- Application of printed tag to the coil

In recent years, the Robotic Tagging Application has been introduced on the market and is gaining in popularity, leaving coil inspection, trimming and sample-collecting as predominantly manual activity in the area.

This is not due to a lack of trying, decades ago the High-Speed Trimming Shear (HSS) was introduced, and under specific conditions and on certain steel grades, it is a successful solution. However, since it is typically located before the formation of the final metallurgical properties of the wire, a manual inspection, trimming & sampling station must often remain to finish the job.

There have also been attempts to trim and sample on the cooling conveyor as well as in the coil forming chamber, and even if a working solution were to exist, it would most probably need a manual inspection, trimming & sampling station to complete the activity. Over the years, there have been several attempts to develop semi-automatic and fully automatic solutions to replace the human operator at the trimming station; performing some, or all, of the human activities by more or less elaborate technical solutions.

## **COMMON PRACTICES**

Manual trimming & sampling requires that the operator count individual rings in a process referred to as “Ring Counting”. It is the dominating method of selecting and separating wire to be trimmed and removed from a coil, the reason for its popularity is that it’s the most practical way for a human to manage the process in a reasonably fast, safe and accurate manner.

Manual trimming & sampling is normally conducted on the exposed end of the wire rod coil as it is presented to the operator supported by either a horizontal C-Hook or a tilted vertical stem-pallet. The process involves several steps which aim to separate the forwardmost rings from the coil followed by counting the desired number of rings plus one or two extra loops just to be on the safe side before making the cut. The cut rings are then removed by the operator and placed into a scrap container. If a sample is required, the operator can quickly cut a sample wire from the trimmed coil before the C-Hook, or tilted pallet, is released.

The defining activity in the above process is the actual counting of rings, and the trimming process above can therefore be referred to as a “Ring Counting Process”. Various tools and equipment have been developed over the years to make this work less cumbersome and hazardous to the operator. However, the basic Ring Counting Process is the same.

## **A NEW PROCESS**

Any trimming method based on the Ring Counting Process has inherent problems with precision and uniformity. Rather than calculating an approximate number of rings on a C-Hook, or a tilted pallet, and cutting at an approximate location along the selected loop, a more accurate method would involve measuring the distance along the wire, taking into consideration the information already available from actual production parameters in the rolling mill.

Before it is possible to measure the distance with some level of accuracy, the actual end of the wire must be located. Once the end is located, the process must be able to measure along the wire until the exact position where the prime quality product begins.

Once the exact position is reached, the system must be able to cut the wire, regardless of where this happens to be along the wire-loop.

Any optimal trimming process must therefore include the following steps:

- Locate the end of the wire
- Measure from the end of the wire to the exact cut-position
- Making a cut at the exact position

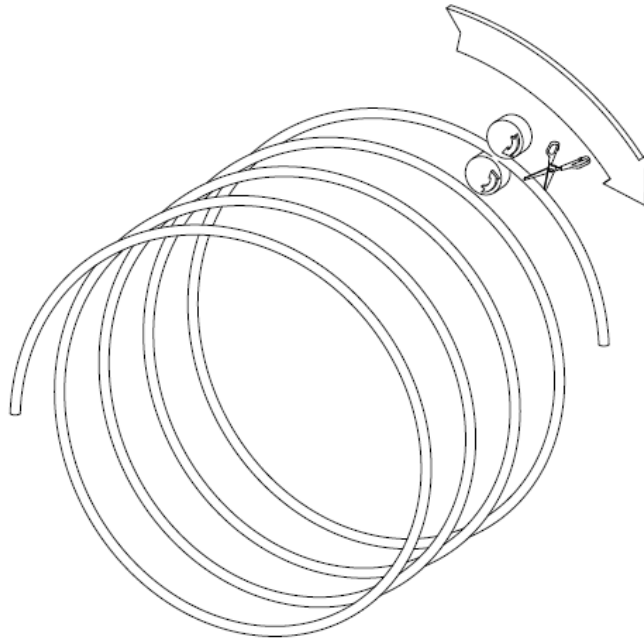

**Figure 1.** Illustration of the principle of moving the cutting tool along the circular shaped helical wire-loop

### **A NEW TYPE OF MACHINE**

Any solution able to perform the new process must also preserve the orderliness of the wire loops within the coil and be gentle and not scratch or damage the finished product.

The only practical way to achieve this is for the machine to feature a similar circular shape to the wire loop it is intended to process.

This resulted in a completely new machine concept referred to as the Ring Processing Turret (RPT).

The Ring Processing Turret is essentially a circular guide with a shape that follows the circular shape of the coiled wire. Distributed along the circular guide is an advanced pinch-roll assembly, a significant number of sensors, several guide segments, and a cutting device. The actual rotation of the Ring Processing Turret is performed by a gearmotor mounted on the Main Trolley.

These distributed resources give the Ring Processing Turret the ability to:

- Receive any ring from the coil into the pinch-roll assembly
- Rotate CW (Clockwise when facing the RPT) towards the end of the coiled wire
- Locate the end of the coiled wire and stop.
- Rotate CCW while measuring the exact position of where to make the trim-cut.
- Locate the trim-cut position and stop, followed by making the trim-cut

- Rotate CCW while measuring the exact position of where to make the sample-cut.
- Locate the sample-cut position and stop, followed by making the sample-cut
- Eject the trimmed rings to be discarded
- Eject the sample wire for testing

Because the RPT perform its process related to the exposed end of the coiled wire, and not related to the system carrying the coil, it can perform its different process-steps regardless of how the coil is oriented.

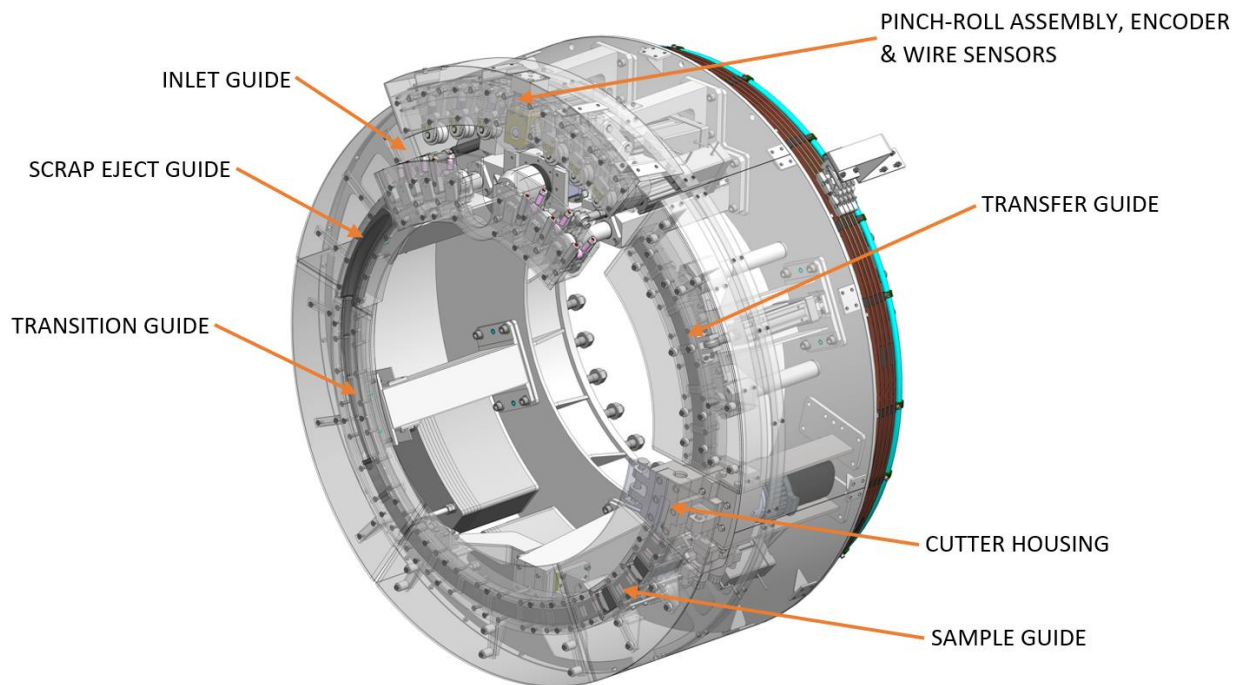

**Figure 2.** Illustration of the Ring Processing Turret

## MAIN TROLLEY

Even though the system can be configured to operate on a horizontal coil or on a vertical coil, a decision was made to design the first TRIMBOT to service the trimming & sampling area in any conventional C-Hook system. This decision was made based on the use of horizontal C-hook systems outnumbering the use of vertical systems by a large ratio.

To move the TRIMBOT to and from the exposed end of the coil while being supported on a C-hook, the system requires a floor-mounted trolley.

The main trolley as depicted in Figure 3, is designed to move the TRIMBOT system from the rest position, located at a safe distance away from the moving C-Hook, to the active forward working position just in front of the C-Hook.

The main trolley consists of a fabricated welded structure equipped with standard roller assemblies intended for the longitudinal rail sections in the rigid base frame mentioned below. The trolley is also equipped with a gearmotor driving a pinion acting on the longitudinal teathed rack on the rigid base frame. This makes it possible for the main trolley to travel along the longitudinal extension of the rigid frame between the different positions.

A separate gearmotor and a large diameter slewing bearing are mounted to the forward part of the fabricated structure. The gearmotor is fitted with a pinion which is acting on the external teeth on the large slewing-bearing which in turn is bolted to the Ring Processing Turret.

Within the main trolley, there is a separate smaller longitudinal rail section, with a separate longitudinal teathed rack. This internal rail structure is intended to support the Internal Ring Transfer trolley as it travels within the main trolley.

A rigid base-frame supports the main trolley. The rigid base frame is designed to be mounted directly onto the existing mill-floor and consists of a fabricated structure with two longitudinal rail-profiles and a longitudinal teathed rack.

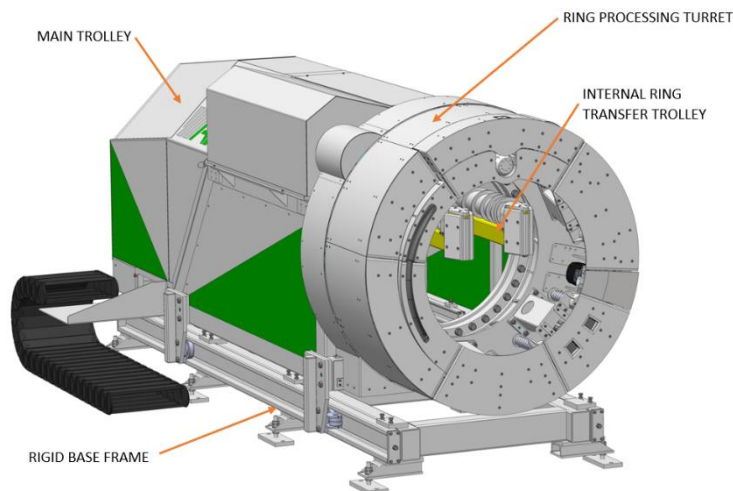

**Figure 3.** Illustration of the Main Trolley with the Ring Processing Turret.

## INTERNAL RING TRANSFER TROLLEY

The internal ring transfer trolley consists of a lower carriage equipped with a gearmotor with a geared pinion. The lower carriage is equipped with standard roller assemblies intended for the longitudinal rail sections within the main trolley mentioned previously.

The lower carriage is also fitted with vertical rails of a similar type as the longitudinal rail sections, intended for supporting the vertical elevator carriage.

The vertical elevator carriage is equipped with standard rollers intended for the vertical rail sections in the lower carriage. The movement up & down along the vertical rails is made possible by an electrical actuator mounted to the lower carriage and acting on the vertical elevator carriage.

The vertical carriage is equipped with two parallel arms extending out from the vertical carriage along the longitudinal axis of the longitudinal rail sections, towards the circular opening in the center of the Ring Processing Turret. At the end of these parallel arms, there are two angled auger-type screws with opposite threads.

The thread pitch on these screws is gradually increasing away from the C-hook to provide a progressively increasing separation between the individual rings as they are transported from the C-Hook to the ring-landing, mounted to each of the two parallel arms. Each of the angled screws is powered by a separate servomotor.

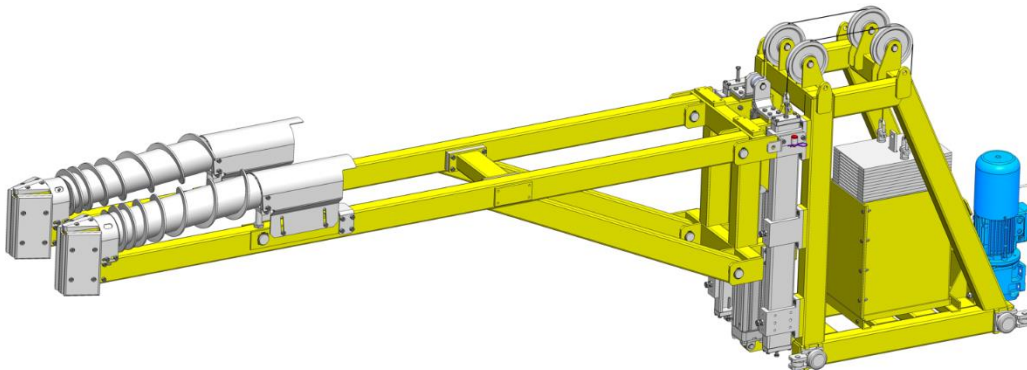

**Figure 4.** Illustration of the Internal ring transfer trolley



## ROBOTIC SYSTEM

In order to find a ring and transfer it into the Ring Processing Turret, as well as to assist in returning any extended rings back onto the C-Hook and to handle the movement of the scrap rings and the sample wire, a robotic arm equipped with a vision system and a wire gripping tool is designed and used to support the system.

The vision system, mounted on the wrist of the robotic arm, allows precise distinction of each ring as they reach the landing in front of the Ring Processing Turret. The vision system captures a 3D image, see Figure 5, which is analysed by dedicated software and enables the gripper to perform an accurate picking of the first ring followed by an accurate placing of the first ring into the extended lower receiving guide within the Ring Processing Turret. The designed gripper will be able to grab both a single ring, a single sample wire as well as the group of rings that need to be scrapped, once the trimming cut has been performed.

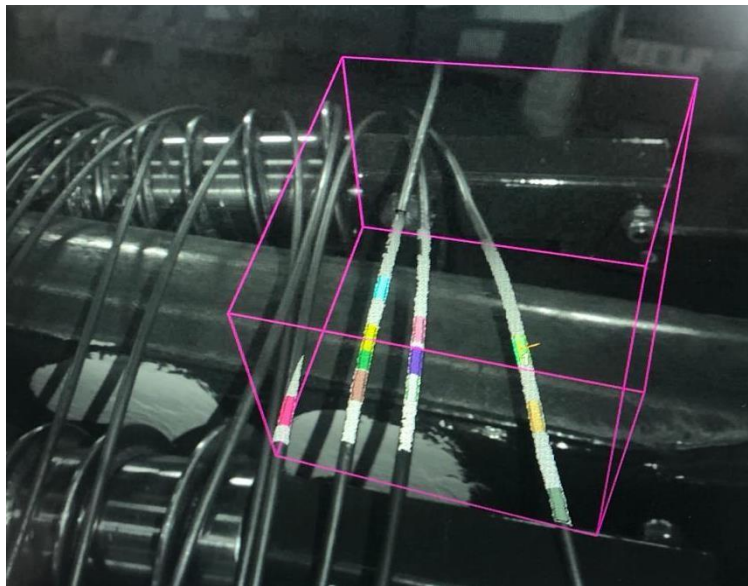

**Figure 5.** Visualization of individual rings detected by the vision system

In order to control the movements of the robotic system, it is commanded by a dedicated control unit which can be configured as a stand-alone unit, or integrated into an electrical cabinet together with the rest of the control units required for the complete automation, including the Ring Processing Turret and all the auxiliary functions.

## ELECTRICAL CONTROL SYSTEM

A dedicated PLC is used to handle all the movements of the machine, including:

- All communications with surrounding equipment, interlocks and trimming/sampling instructions
- Horizontal move of the Main Trolley to allow translation of the whole structure
- Rotation of the Ring Processing Turret & control of motors/actuators within.
- Horizontal and Vertical movement of the Internal Ring Transfer Trolley
- Rotation of the Separating Screws
- Control signals to send to the shear in order to perform the wire cutting
- Position control of the rotating unit to allow a maintenance-friendly configuration
- Interface between the 3D Optical Scan sensor and the image analysis' software
- Control signals necessary for the handling of the end-effector/gripper tool
- Handling of all the distributed sensors data
- Data Exchange with the existing plant automation
- Handling of the Safety accesses to the area

For the Robotic system, a dedicated control unit fully integrated with the automation handles all the movement of the robotic arm and allows the programming of its sequence in terms of target positions to be reached as well as conditional cycles to make sure that the Ring Processing Turret is ready and able to receive the robot's help.

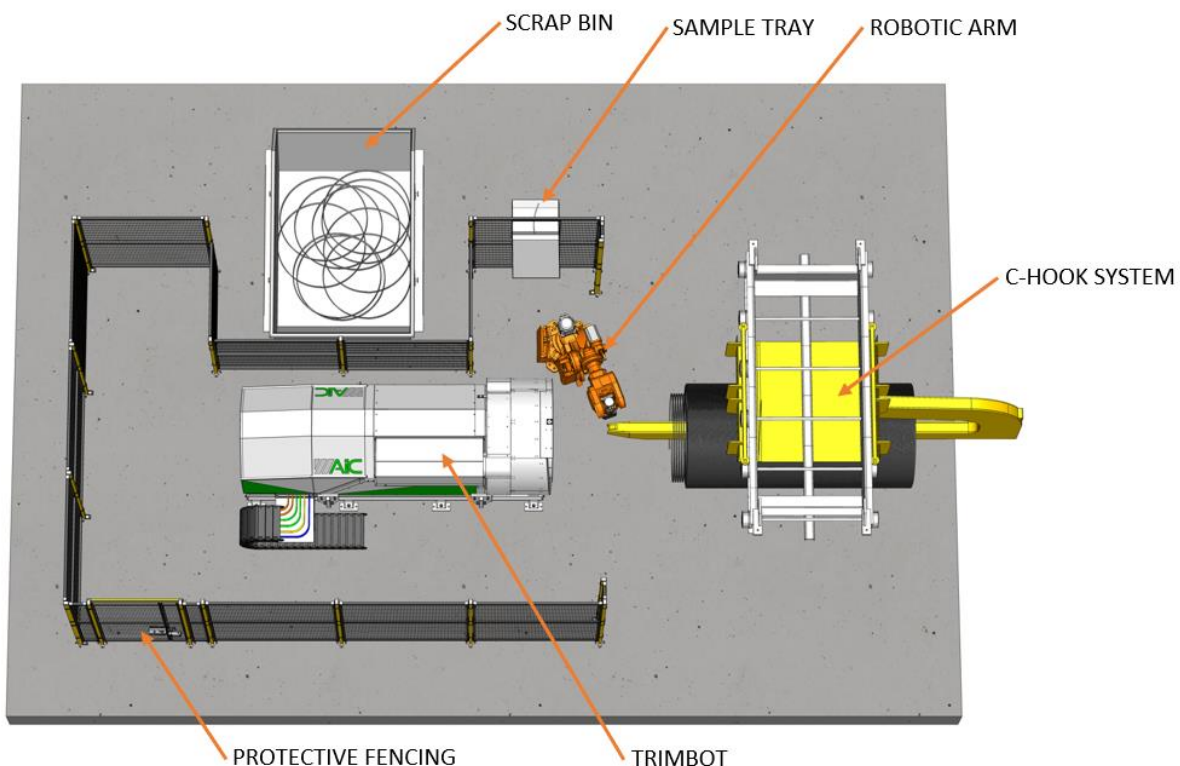

**Figure 6.** Illustration of the TRIMBOT configured at a normal C-Hook coil handling system.

## THE SEQUENCE

The basic sequence, as described below, will likely change as the product & the process evolves over time. However, in this basic configuration, the TRIMBOT is working on a conventional C-Hook system and requires similar interlocks as is used between a typical coil compactor and a C-Hook system.

Preconditions, before the automatic process can commence, are:

- C-Hook in position & locked
- TRIMBOT receives instructions on how much wire to remove and if a sample is required.

Sequential steps to place the initial wire inside the machine

- The main trolley moves forward to the C-Hook and begins to separate loops from the coil.
- Robot arm, supported by a vision system, locate and pick a wire loop
- Wire loop placed into the Ring Processing Turret by the robot arm

Sequential steps to locate the end of the wire

- Ring Processing Turret begins to rotate towards the end of the coil while untangling individual rings
- All movements stop when wire sensors detect the end of the wire.

Sequential steps to measure the distance of where to trim

- Transfer guide within the Ring Processing Turret is extended
- Ring Processing Turret begins to rotate away from the end of the coil
- When the rotary encoder detects that the cut-point is in the center of the shear, the Ring Processing Turret stops
- The shear within the Ring Processing Turret extends its movable blade and the wire is sheared.

Sequential steps to measure the distance of where to cut a sample

- Ring Processing Turret begins to rotate away from the end of the coil
- When the rotary encoder detects that the cut-point is in the center of the shear, the Ring Processing Turret stops
- The shear extends its movable blade and the wire is sheared.

Sequential steps to return trimmed coil to C-Hook

- Ring Processing Turret rotates towards the end of the coil until the new end has exited
- C-Hook is released and a new C-Hook with the coil is allowed to move into position.

Sequential steps to discard trimmed rings

- Main trolley retracts to the unloading position
- Robotic arm with a vision system identifies the trimmed rings and moves in position to grip trimmed rings
- Gripper closes on trimmer rings and the robotic arm transfers them to the scrap bin.

### Sequential steps to discard sample wire

- Main trolley moves to the sample receiving position
- The sample guide extends and exposes the sample wire
- Robotic arm with a vision system identifies the sample wire and moves in position to grip the sample wire
- Gripper closes on the sample wire and the robotic arm transfers them to the sample tray

After completing the trimming and/or sampling sequence, the TRIMBOT returns to its start position and waits for a new start sequence. The estimated time required to perform any single trimming sequence is 45-60 seconds, depending on the length of wire that must be trimmed and removed. A single sampling sequence will add approximately 20 seconds to the above trimming sequence. The trimming capacity is limited to the payload of the robotic arm. The current configuration is limited to 100 kg in a single lift.

# CONCLUSION

The completely electrical TRIMBOT is designed to fit and operate in almost any existing coil handling system with minimum disturbance to the existing operation, or to be incorporated in new systems already during the concept design stage. It is primarily designed to replace any existing Ring Counting Process, but its value to the rolling mill extends beyond only replacing the human operators in finishing-end areas by offering a level of trimming accuracy that isn't possible on a "ring-counting" trimming method.

The novel trimming process makes possible to reach a trimming accuracy of +/- 5 mm under certain conditions. At this level of accuracy, the Dynamic Trimming feature helps to further reduce waste & yield losses.

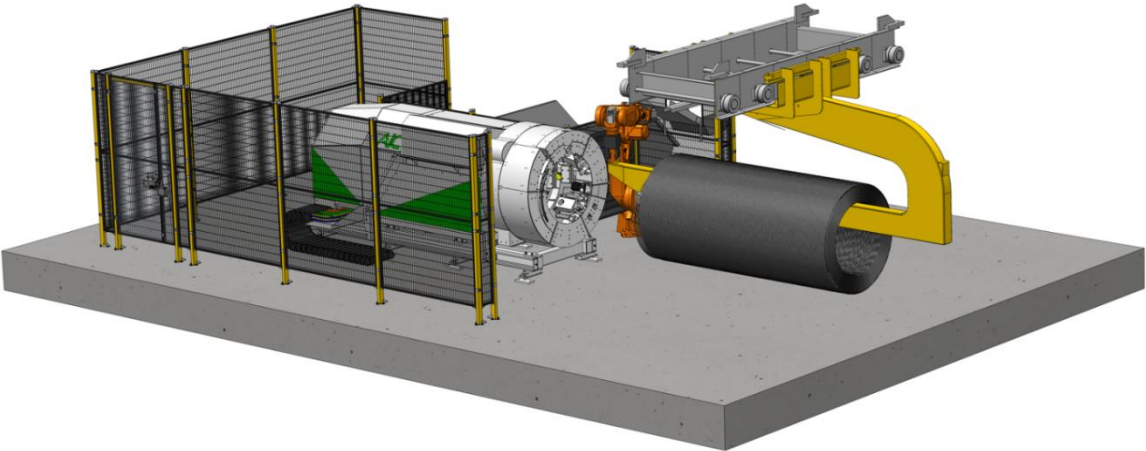

**Figure 7.** Illustration of the entire TRIMBOT station.

And, for the first time, these activities can be performed while the coil remain vertical.

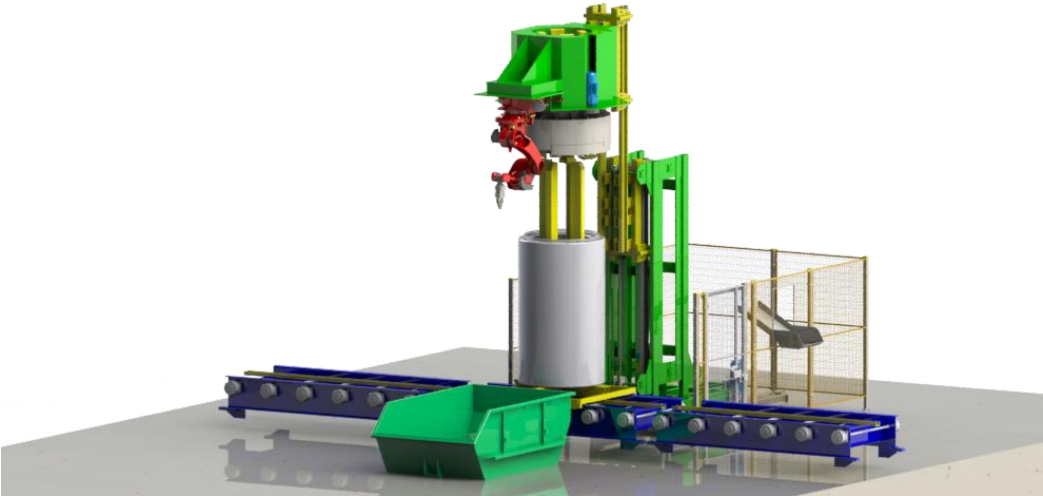

**Figure 8.** Illustration of TRIMBOT station in vertical configuration.